

MODULATOR BASED ON K15-10 CAPACITORS FOR A POWER SUPPLY OF THE KIU-12 KLYSTRON

V.E. Akimov, P.A. Bak, R.H. Galimov, I.V. Kazarezov, A.A. Korepanov, N.H. Kot
Budker Institute of Nuclear Physics, Novosibirsk, Russia

KIU-12 klystrons, the most powerful among serial domestic microwave devices of a ten-centimeter range, have found wide application in scientific laboratories of the countries of CIS. In the Institute of Nuclear Physics SB RAS that klystron is used in a complex research of accelerating system units for VEPP-5 preinjector prototype [1]. The klystron was powered by a standard modulator on the basis of a double pulse forming network (PFN), obtained from NSC KIPT (Ukraine). Unfortunately, the long-term operation of the modulator in NSC and further in INP SB RAS has caused the failure of a main modulator component – pulse forming network assembly. Therefore there was a necessity to modify the modulator on the basis of available capacitors K15-10 of 0,01 μF capacitance on voltage of 40 kV.

The circuit features, design, and operational experience of the pulse forming network (PFN) are described below.

PFN DESIGN

PFN is of a blumlein type because the pulse transformer design remains the same (transformer turns ratio $K=7$). The characteristic impedance of the network is half the klystron load impedance relative to the primary winding of the pulse transformer. Service experience obtained during development and maintenance of numerous facilities based on the capacitors considered above [2, 3, 4] has been taken into account in PFN design.

Previous research [2, 5] revealed that the main cause of capacitor breakdown is associated with the partial discharges at the washer area. The washer is brazed to the silver coating and serves as a terminal for connecting and supporting the capacitor. Therefore capacitors of lead-free design are used in PFN in order to increase its reliability and exclude capacitor failures due to partial discharges.

PFN (Fig.1) consists of 12 capacitor sections (1) (6 sections for each half-line), each section contains 8 capacitors (2), series-parallel connected with one another in each cell. Springs made of beryllium bronze (3) are installed to provide an electric contact between the capacitors, a section is tied by steel studs (4). Given the insufficient capacitance of every capacitor (average capacitance is 9000 pF), the total PFN capacitance is 0.215 μF .

The coil design (5) allows us to tune the network bodily by shifting the core (6) within the coil.

The transformer oil is used as an insulation media.

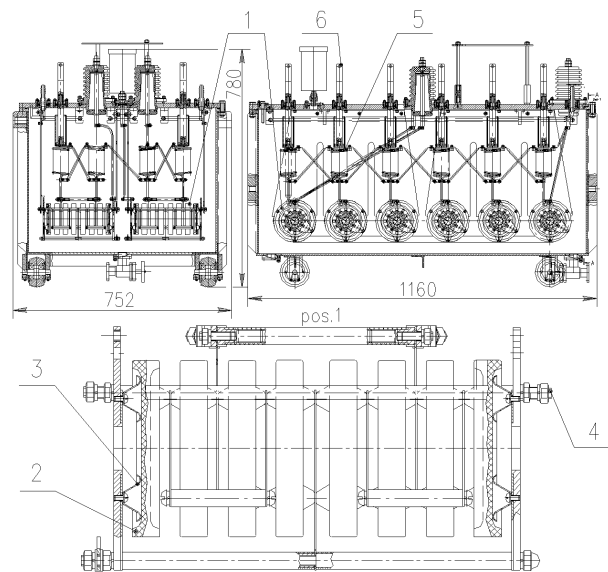

Fig. 1: PFN design.

SPECIAL FEATURES OF THE MODULATOR CIRCUIT

Fig. 2 represents the simulation circuit of a blumlein type PFN. Two end of line clipper (EOLC) systems R1-D1 and R2-D2 are the special features of this circuit. R1-D1 circuit is placed in parallel with a thyatron to limit the thyatron inverse voltage. R2-D2 circuit is needed for dissipation of energy retained in pulse transformer magnetization inductance $L\mu$ at the end of pulse voltage on the klystron. These EOLC systems limit the maximal voltage difference on PFN capacitors, therefore their service life increases. The thyatron in the circuit is represented as an ideal switch S and diode $D3$. The resistor $R2$ is chosen so that in the process of dissipation of energy stored in $L\mu$ of the pulse transformer, PFN capacitance does not recharge, and voltage undershoot on the klystron does not exceed safe limits. Therefore, resistance $R2$, on the one hand, should be small enough, but, on the other hand, small value of $R2$ leads to increasing of an average current through the diode. The optimal value $R2=60$ Ohm has been chosen by simulation of processes in the circuit shown on Fig.2. Value of resistance $R1$ has an effect on both the voltage undershoot on the thyatron and on oscillation processes in PFN after a pulse, i.e. oscillations in PFN will be damped slower if $R1$ appreciably differs from PFN characteristic impedance of 14 Ohms.

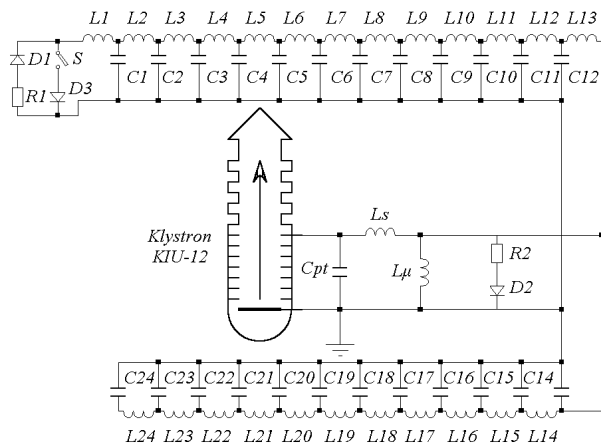

Fig. 2: PFN simulation circuit.

Simulation of these processes shows, that at $R1=14$ Ohms the inverse voltage applied to the thyatron after cut-off does not exceed the maximum safe value. Current and voltage curves in circuit elements in a process of voltage pulse forming on the load are shown in Fig.3.

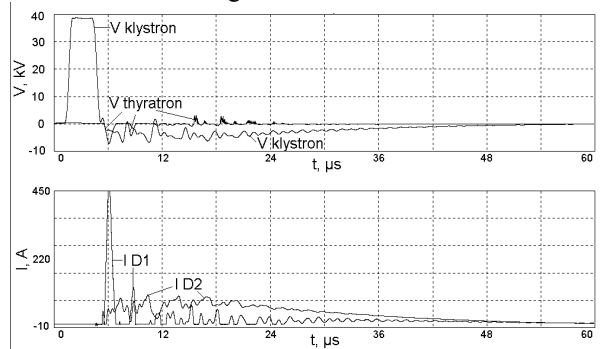

Fig. 3: Current and voltage curves in PFN circuit elements.

Diodes $D1$ and $D2$ were assembled of high-voltage stacks SDL 800. $D1$ is 2 diodes connected in parallel, and $D2$ is 4 diodes. Resistors $R1$ and $R2$ are assembled from resistors of TVO-60 type. Power dissipated in $R1$ is ~ 100 W, and in $R2$ is ~ 350 W. Circuits described above are located on the tank cover of PFN.

FEATURES OF KIU-12 KLYSTRON CONTROLS

A klystron control circuit is equipped by “Regime and protection” unit, which scans every pulse

of modulator and klystron operation. In the case of forward or inverse overvoltage on PFN or rectifier, start of the thyatron is cancelled. It is also cancelled when a voltage on the klystron exceeds 300 kV in the previous pulse, as well as at klystron electron beam perveance decreasing, with loss of vacuum in the klystron, and after three-fold discharge inside the klystron. In the case of discharge on the klystron dielectric window surface or in the waveguide section the klystron continues to operate in diode mode, and input RF power pulse is shifted by 100 μ s relative to the modulator pulse. After one-minute delay the pulses are brought together automatically. Every case of non-nominal operation is indicated by a LED on “Regime and protection” unit’s panel.

RESULTS OF THE WORK

The modulator based on PFN described above has been operated during several hundreds hours at a PFN charge voltage $U=20$ kV and repetition rate of 50 Hz. At present the klystron and modulator are used for RF power supply of a photogun cavity of VEPP-5 injection complex. PFN testing at operating conditions under a voltage of 40 kV will be carried out in the future.

REFERENCES

- [1] M.S. Avilov et al., Prototype of VEPP-5/preinjector. – Atomic science and technics issues , “Nuclear physics research” series, 1997, is. 2,3, 206 p. (in Russian).
- [2] S.B. Vasserman et al., High-voltage capacitance pulse power accumulator. – Preprint INP 80-129, Novosibirsk, 1980 (in Russian).
- [3] Electron beam generator for a prototype of VLEPP RF generator./ V.E. Balakin et. al. – In: Atomic science and technics issues, “Physical experiment technics” series. Kharkov, 1982, is. 1(10), pp. 6-8 (in Russian).
- [4] I.V. Kazarezov, Sitall Capacitors in High Voltage Pulse Generators, Proceeding of the VII International Workshop on Linear Colliders, Sept. 29-Oct. 3, 1997 Zvenigorod, Russia.
- [5] I.V. Kazarezov, Pulse electron beam source for powerfull RF oscillations of centimetric range generation. – PhD thesis, Novosibirsk, 1985, 153 p. (in Russian).