

CONTROL OF REDUCED ELECTRIC FIELD IN THE POSITIVE COLUMN OF A PULSED DISCHARGE IN CO₂

V.A. Lisovskiy, S.V. Dudin, M.M. Vusyk, R.O. Osmayev, V.D. Yegorenkov, P.P. Platonov

V.N. Karazin Kharkiv National University, Kharkiv, Ukraine

E-mail: lisovskiy@yahoo.com

The electric field strength in the positive column of dc and bipolar pulsed discharges in carbon dioxide was determined by the method of moving electrodes. It is shown that an increase in the frequency of the pulse voltage leads to the electric field strength increase. The following values of the reduced electric field E/p for a gas pressure of 0.5 Torr were obtained: 22.5 V/(cm·Torr) for dc discharge, 30 V/(cm·Torr) for pulsed discharge at 20 kHz for low-current mode and 32 V/(cm·Torr) for high-current mode, and 36.6 V/(cm·Torr) for 75 kHz. We see that in the dc discharge, the reduced electric field is weak, due to which the exchange of vibrational energy between CO₂ molecules dominates the conversion process. The increase of the electric field strength in the positive column of a pulsed discharge, especially under conditions of gas heating, allows obtaining $E/N > 100$ Td when the process of direct dissociation of CO₂ molecules by fast electrons makes the main contribution to the conversion process.

PACS: 52.77.-j, 82.33.Xj

INTRODUCTION

The permanent growth of carbon dioxide concentration in the earth's atmosphere due to the intensive combustion of fossil hydrocarbons enhances the greenhouse effect and significantly affects the climate. Therefore, the reduction of CO₂ emissions into the atmosphere and the processing of carbon dioxide (in the exhaust gases of thermal power plants, previously pumped into underground storage facilities or already released into the atmosphere) into raw materials for the chemical industry, various types of fuel is of great importance. Plasma methods for such conversion of CO₂ are among the most promising and effective, so a large number of scientific groups are working on this topic [1-6].

The governing similarity parameter for the CO₂ plasma conversion process is the reduced electric field E/N (where E is the electric field intensity, N is the concentration of gas molecules) and the electron temperature T_e corresponding to it [1, 2]. The share of power deposited in the process of dissociation of CO₂ molecules depends just on E/N . If the reduced electric field E/N in the discharge chamber does not exceed 100 Td (high gas pressure, weak electric field), the main contribution to the conversion will be the excitation of molecular vibrations by low-energy electrons. If $E/N > 100$ Td, then the process of direct dissociation of CO₂ molecules by fast electrons will dominate [1, 2]. Discharges of different types are either dominated by one of the conversion mechanisms, or simultaneous operation of both mechanisms is observed.

In our previous studies, the processes of carbon dioxide conversion in the inductively coupled plasma (ICP) were investigated both experimentally [7] and with kinetic modeling [8]. In low-pressure discharges, the conversion coefficients were also measured in magnetron and ion-beam plasmas [9]. Under the conditions of [7-9], the process of direct dissociation of CO₂ molecules by electron impact dominates. In dc glow discharges, which are maintained at a higher pressure, either both mechanisms can participate in the conversion (in the negative glow of

discharges with flat [10, 11] or hollow [12] cathodes), or the conversion due to energy exchange between vibrationally excited molecules dominates (for example, in the positive column of the discharge [10]).

In order to carry out the carbon dioxide conversion effectively, it is desirable to develop methods of controlling the reduced electric field. An increase in E/N will enhance the direct dissociation of CO₂ molecules by electron impact, and its decrease will make the exchange of vibrational energy between excited carbon dioxide molecules play a dominant role in the conversion process. In this research, the value of E/N in bipolar pulsed and dc glow discharges was measured by the method of moving electrodes. It is shown that an increase in the pulse voltage frequency allows for increasing the value of E/N in the positive column.

1. EXPERIMENTAL

The simplified scheme of the experimental setup is shown in Fig. 1. The glass discharge tube had an internal diameter of 56 mm. One of the metal terminating flanges was a fixed electrode to which voltage from the pulse generator was applied. A movable electrode was introduced through the opposite flange. Both electrodes were flat and made of stainless steel. The distance between them varied from 5 to 150 mm. A bipolar pulse voltage (up to 1100 V peak-to-peak) was applied to the potential electrode via a capacitor. Experiments were carried out for two frequency values of 20 and 75 kHz in a wide duty-cycle range from 11 to 95 %. Oscillograms of pulse voltage and current were measured with the oscilloscope PCS500 (Velleman Instruments). Their further analysis was carried out with the help of a personal computer. To reduce gas heating by the concentration of its molecules, discharge current values did not exceed 60 mA.

In addition, experiments with direct current discharge were conducted in the same chamber. A constant voltage from the power source was applied to a fixed electrode, which acted as a cathode. The moving electrode was a grounded anode.

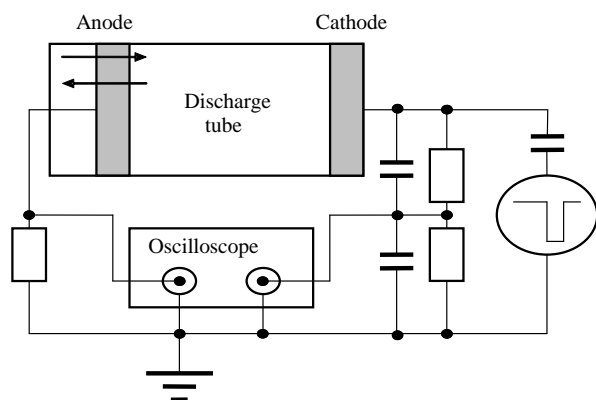

Fig. 1. The scheme of the experimental setup

Carbon dioxide was injected into the discharge chamber to a pressure of 0.5 Torr using a mass-flow controller (STEC SEC 4400). The gas flow was 20 sccm. Capacitance gauge Baratron 627 (MKS Instruments) with the maximum measured pressure value of 10 Torr was used to measure gas pressure.

The electric field strength in the plasma is usually measured by Langmuir probes (double or single). But the probe can significantly disturb the plasma, and in a number of studies [13, 14], the moving anode method was used to measure the axial distribution of the electric field strength in the positive column of dc discharge. The use of this method does not disturb the plasma and allows to study of a large number of processes in the discharge tube during one experiment [15].

If the anode is placed near the very edge of the cathode layer, one can first observe an obstructed discharge with a high voltage between the electrodes. Further, the distance between the electrodes is increased, while the discharge current is kept fixed, and the voltage between the electrodes is measured. As the distance between the cathode and the anode increases, a negative glow, a dark Faraday space, an anode glow, and then a positive column appear successively. The characteristics of the positive column do not depend on the processes in the cathode layer. If the anode is located in the uniform positive column, then the increase in the distance between the electrodes is accompanied by the linear increase in the voltage between the electrodes. This makes it possible to measure the strength of the axial electric field in the positive column.

We used just this method in the presented research. The anode was always placed in the positive column. When the distance between the electrodes increases from L_1 to L_2 , the length of the positive column increases by $|L_1 - L_2|$, while other parts of the discharge remain unchanged. This is accompanied by an increase in the voltage drop between the electrodes by ΔU . Thanks to this, we can determine the electric field strength $E = \Delta U / |L_1 - L_2|$. Features of the application of this technique for pulse discharge will be considered below.

1. EXPERIMENTAL RESULTS FOR PULSED DISCHARGE

First, consider the results obtained for the impulse discharge. Note that impulse discharges are less studied than the well-known direct current discharges. The pulsed discharges may be unipolar [16-18] or bipolar

[19]. In a unipolar discharge, during some part of the pulse (which is determined by the duty cycle D), a high voltage is applied to the potential electrode, which forms a discharge. Then the voltage decreases to zero, and during the pause, the discharge plasma decays (completely or partially). A new voltage pulse leads to a repeated breakdown of the gas (or a renewal of the discharge, if the plasma did not have time to disintegrate completely during the afterglow). In a bipolar discharge, when the pulsed voltage source is connected to the electrode via a capacitor, the electrodes alternately play the role of the cathode. The voltage amplitude in each phase depends not only on the peak-to-peak voltage U_{pp} , but also on the duty cycle D . These amplitudes differ and are equal to each other only at $D = 50\%$. If $D > 50\%$, a negative voltage U_{neg} is applied to the right electrode during the first part of the pulse, greater than the voltage U_{pos} , which will be applied to the left electrode during the second part of the pulse. This allows not only to change the magnitude of the discharge current during the first and second parts of the pulse but also to control the discharge burning modes. Note that the bipolar pulse discharge can burn in low-current and high-current modes [19], the properties of which will be considered below.

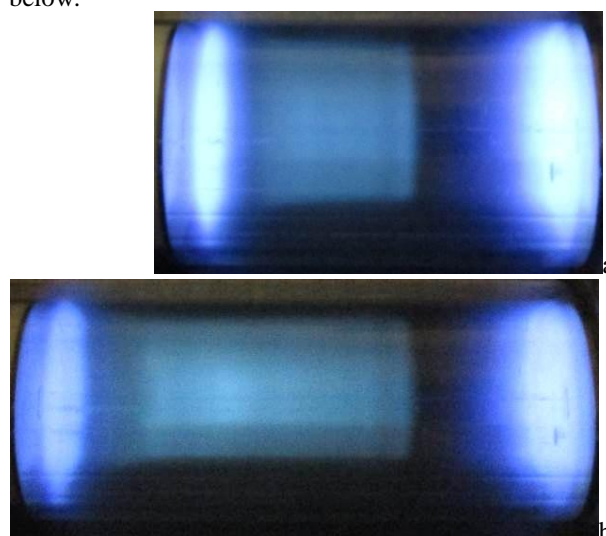

Fig. 2. Photographs of the high-current mode of pulsed discharge ($f = 20$ kHz, $D = 85\%$):

a – $L = 100$ mm, $U_{pp} = 989$ V;
b – $L = 150$ mm, $U_{pp} = 1073$ V

The purpose of our research is to find a technique for controlling the magnitude of the reduced electric field E/N in the positive column of pulsed discharge. To do this, we will investigate how the electric field strength in the positive column changes in response to the frequency change. It was shown in [19] that the change in duty cycle D significantly affects the structure of bipolar pulse discharge. At $D = 50\%$, the positive column becomes the shortest, while it is usually strongly stratified. If $D \approx 10\text{--}20\%$ (or $D \approx 80\text{--}90\%$), the length of the positive column is the largest, and it becomes more uniform. Therefore, during our experiments with pulsed discharge, the duty-cycle was equal to $D = 85\%$.

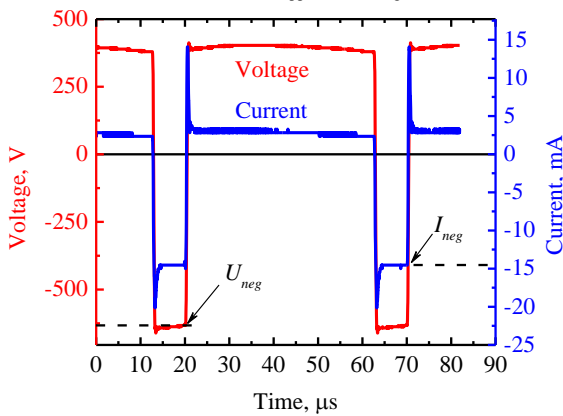

Fig. 3. Oscillograms of voltage and current of the high-current mode of pulsed discharge: $f = 20 \text{ kHz}$, $D = 85 \%$, $L = 150 \text{ mm}$, $U_{pp} = 1073 \text{ V}$

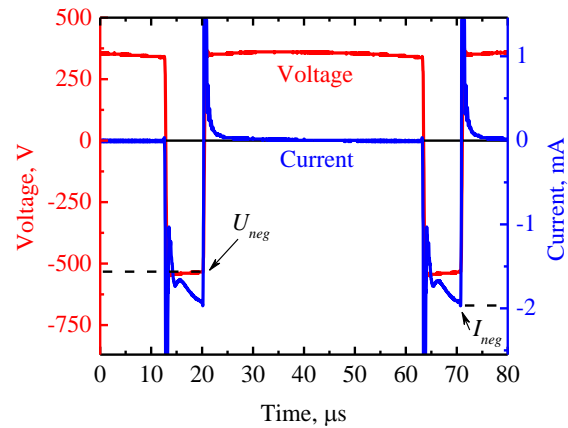

Fig. 5. Oscillograms of voltage and current of the low-current mode of the pulsed discharge: $f = 20 \text{ kHz}$, $D = 85 \%$, $L = 100 \text{ mm}$, $U_{pp} = 938 \text{ V}$

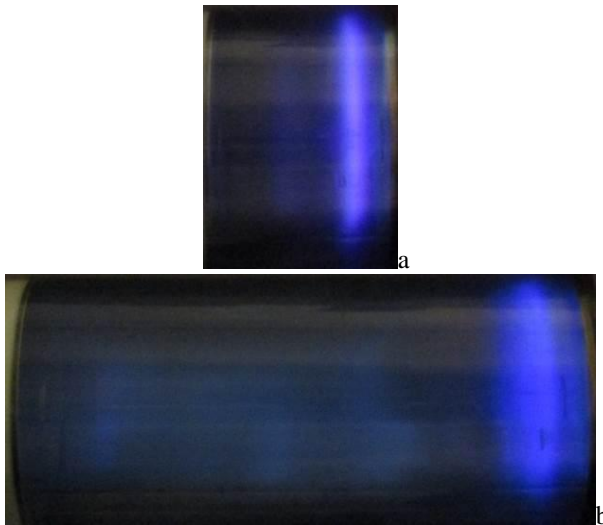

Fig. 4. Photographs of the low-current regime of pulsed discharge ($f = 20 \text{ kHz}$, $D = 85 \%$):
 a – $L = 35 \text{ mm}$, $U_{pp} = 844 \text{ V}$;
 b – $L = 120 \text{ mm}$, $U_{pp} = 975 \text{ V}$

Let's consider the low-current and high-current modes of the bipolar pulsed discharge for a frequency of 20 kHz. Fig. 2 shows the high-current mode for two distances between the electrodes. Due to the large duty cycle, the discharge is asymmetric. One can see cathode layers and negative glows near both electrodes. But the electrodes voltages differ significantly. Fig. 3 shows oscillograms of the voltage and current. It is seen that when the right electrode is the cathode, the negative voltage on it exceeds 650 V, while when the left electrode is the cathode, the voltage on it is about 400 V, which leads to the asymmetry of the discharge. A stream of high-energy electrons exits from the right cathode layer, as a result of which we see the longer negative glow and dark Faraday space near the right electrode. At the moment of applying high voltage to the right electrode, a strong current surge is present, which consists of the displacement current and the discharge current that is formed at this time [18]. The discharge current is then reduced to I_{neg} , which we will further monitor during our experiments. In high-current mode, the discharge burns stably during both parts of the pulse.

Now consider low-current mode. Fig. 4 shows the discharge photos for two distances between the electrodes, and in Fig. 5 one can see the corresponding voltage and current oscillograms. During the first part of the pulse, the voltage applied to the right cathode exceeds 550 V, while after the surge and decay of the reactive current, the discharge current continues to increase. This means that during the first part of the pulse, in the low-current mode, the discharge does not have time to fully form. Moreover, the voltage applied to the left electrode during the second part of the pulse (360 V) turns out to be insufficient to maintain the discharge, and the discharge current decreases to zero after the reactive peak. That is, during the second part of the pulse, we see the afterglow, the decaying plasma. Therefore, when a new voltage pulse is applied to the right cathode, the discharge should ignite again, and the discharge current barely reaches 2 mA. Nevertheless, during the first part of the pulse, we can see the formation of a positive column, which glows weakly due to the small amount of discharge current.

We have similar results for the frequency of 75 kHz. Fig. 6 shows photos of the high-current mode, and Figs. 7 and 8 show voltage and current oscillograms for high-current and low-current modes, respectively.

As for the lower frequency, at 75 kHz, the discharge quickly decays during the second part of the voltage in low-current mode. But a positive column is observed. Photos of low-current mode for 75 kHz are practically the same as for 20 kHz, so we do not show them.

Note that if you change the distance between the electrodes while keeping the value of the discharge current I_{neg} at the end of the first part of the pulse fixed, the voltage on the left electrode during the second part of the pulse changes slightly (Fig. 9). In fact, the displacement of the movable electrode affects only the U_{neg} voltage applied to the right electrode-cathode, for both low-current and high-current modes. This allows us to apply the technique of measuring the electric field strength in the positive column (which was developed for dc discharge) to bipolar pulse discharge.

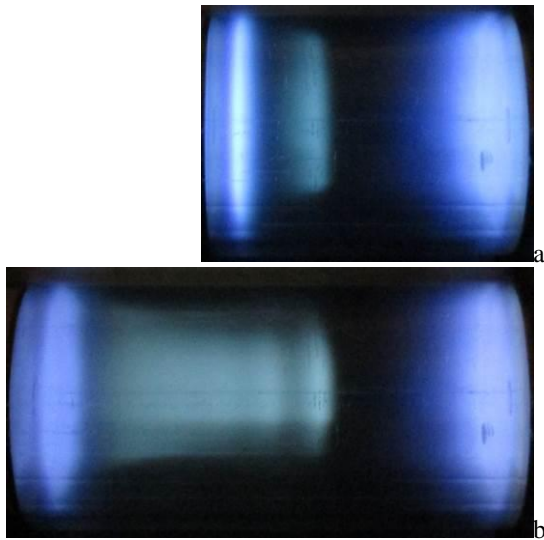

Fig. 6. Photographs of the high-current regime of the pulsed discharge ($f = 75$ kHz, $D = 85$ %):
 a – $L = 75$ mm, $U_{pp} = 970$ V;
 b – $L = 120$ mm, $U_{pp} = 1055$ V

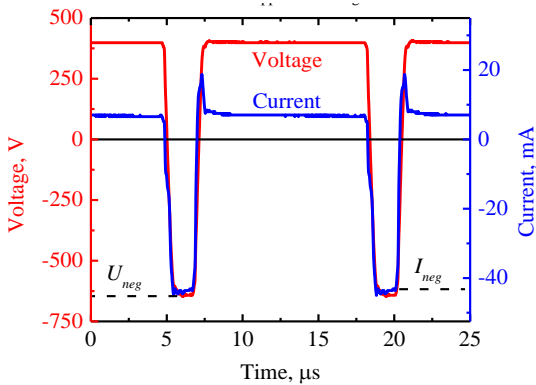

Fig. 7. Oscillograms of voltage and current of the high-current regime of the pulsed discharge ($f = 75$ kHz, $D = 85$ %, $L = 85$ mm, $U_{pp} = 1055$ V)

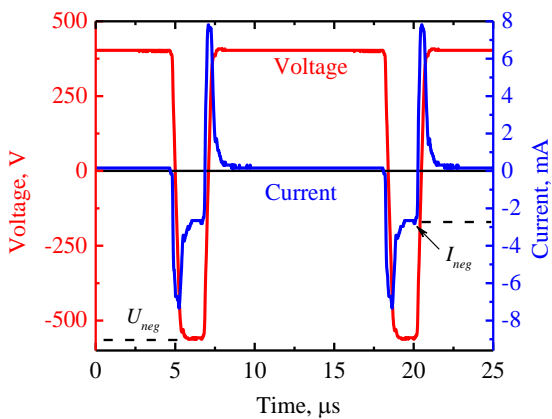

Fig. 8. Oscillograms of voltage and current of the low-current mode of the pulsed discharge ($f = 75$ kHz, $D = 85$ %, $L = 100$ mm, $U_{pp} = 980$ V)

The measured dependences of U_{neg} on the distance between the electrodes for low-current and high-current modes are shown in Figs. 10 and 11 for frequencies of 20 and 75 kHz, respectively. From the slope of the straight lines approximating the given dependencies, we get the electric field strength of 15 V/cm for low-current

and 16 V/cm for high-current modes for a frequency of 20 kHz. Increasing the frequency to 75 kHz led to an increase in the electric field strength to 18.3 V/cm for both discharge modes. We take into account that the measurements were carried out for the pressure of carbon dioxide $p = 0.5$ Torr, therefore the reduced electric field for the given cases is equal to $E/p = 30, 32$, and 36.6 V/(cm·Torr). We see that to maintain the positive column in the pulsed discharge with the increased frequency, a higher value of the reduced electric field E/p is required.

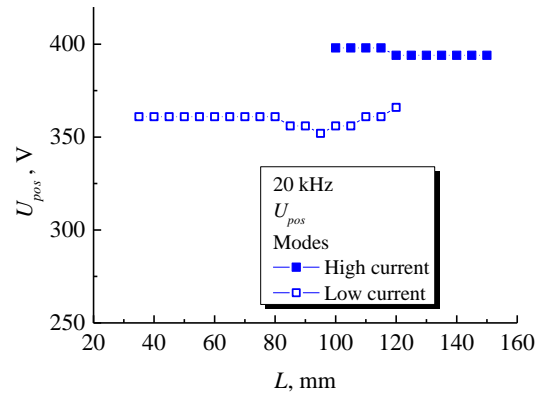

Fig. 9. Dependence of the voltage during the positive part of the pulse on the inter-electrode distance for the low-current and high-current modes ($f = 20$ kHz)

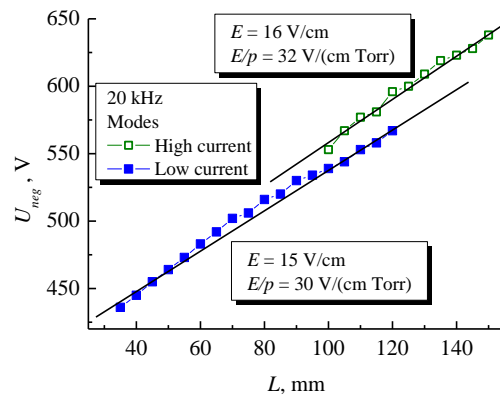

Fig. 10. Dependence of the voltage during the negative part of the on the inter-electrode distance for the low-current and high-current modes ($f = 20$ kHz)

3. EXPERIMENTAL RESULTS FOR DC GLOW DISCHARGE

The positive column of the dc discharge under the conditions of our experiments is stratified. The displacement of the movable anode through the stratified positive column is accompanied by small voltage oscillations between the electrodes, which correspond to the voltage drop on each individual layer [15]. Therefore, we will actually measure the average value of the electric field strength. Fig. 12 shows a photo of the dc discharge, in which the cathode is on the right, and on the left we see the anode, to which the anode glow is attached, and next, we see the stratified positive column. An increase in the discharge current leads to a decrease in the length of the positive column. So, during this ex-

periment, we first placed the anode at a distance of $L_1 = 350$ mm, ignited the discharge, measured the voltage between the electrodes, which corresponds to the current, for example, 3 mA, then slowly shifted the anode to the distance between the electrodes $L_2 = 250$ mm (while maintaining a fixed amount of current) and measured the voltage again. Next, such measurements were repeated for a different current value. The measured dependencies of the voltages between the electrodes for these distances L_1 and L_2 are shown in Fig. 13. From them, we determined the values of the reduced electric field E/p , which are shown in Fig. 14. We see that in a wide range of discharge currents, the average value of the reduced electric field is $E/p = 22.5$ V/(cm·Torr), which is significantly less than for the pulsed discharge.

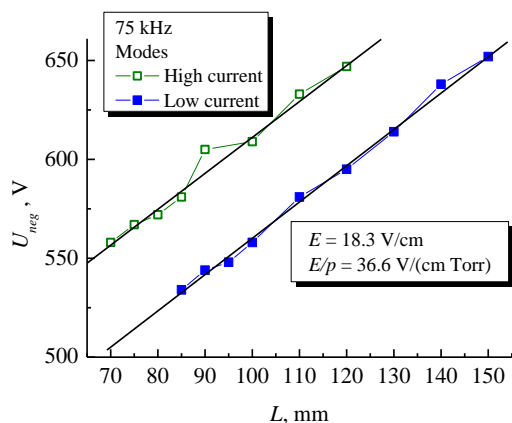

Fig. 11. Dependence of the voltage during the negative part of the pulse on the inter-electrode distance for the low-current and high-current modes ($f = 75$ kHz)



Fig. 12. Photograph of dc discharge for a current of 3 mA and a distance between the electrodes $L = 350$ mm

Note that the value of E/p obtained by us in the positive column of a dc discharge in CO_2 is consistent with the results of paper [20], the authors of which obtained $E/p = 28$ V/(cm·Torr) for the pressure of 0.5 Torr. The neutral gas temperature obtained by them in the current range of 10...80 mA was in the range of 360...410 K while the walls of the discharge tube were maintained at a fixed temperature of 323 K (50 °C), and the inner diameter of the tube was equal to 2 cm. It can be estimated that the gas temperature in our tube with an inner diameter of 5.6 cm in the same current range was 50...60 °C. Table shows the values of E/p and E/N for dc discharge and pulse discharge in different modes.

One can see that in the positive column of pulsed discharge at room temperature, the value of E/N reaches and even exceeds 100 Td, while the gas heating by the discharge current increases the reduced field. That is, if in the positive column of the dc discharge the conversion process is controlled by the exchange of vibrational energy between excited CO_2 molecules, then the use of

a pulsed discharge with a sufficiently high frequency allows the dominance of the process of direct dissociation of CO_2 molecules by fast electrons.

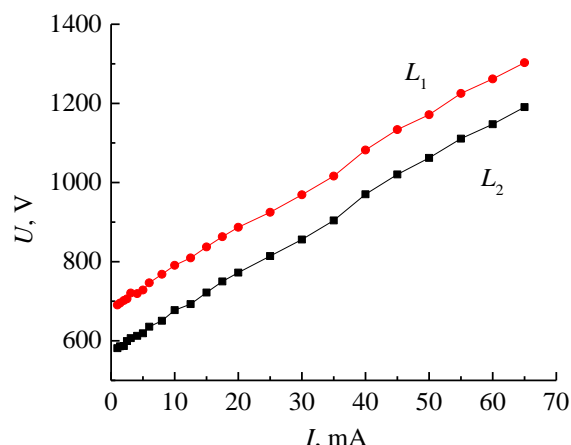

Fig. 13. Dependence of the discharge voltage on discharge current for distances between electrodes $L_1 = 350$ mm and $L_2 = 250$ mm

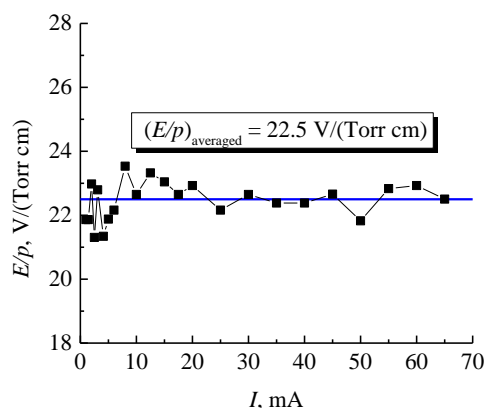

Fig. 14. Dependence of the reduced electric field E/p on the discharge current

Reduced electric field at different modes

Frequency	E/p , V/(cm·Torr)	E/N (20 °C), Td	E/N (100 °C), Td
DC	22.5	68	87
20 kHz LC	30	91	116
20 kHz HC	32	97	124
75 kHz LC	36.6	111	142
75 kHz HC	36.6	111	142

CONCLUSIONS

In the present research, we measured the electric field strength in the positive column of dc and bipolar pulsed discharges for a carbon dioxide pressure of 0.5 Torr. The obtained values of reduced electric field E/p range from 22.5 V/(cm·Torr) for dc discharge to 36.6 V/(cm Torr) for pulsed discharge at 75 kHz. This provides direct control of the field allowing transition from the weak-field regime (when the exchange of vibrational energy between CO_2 molecules makes the main contribution to the conversion process in the positive column) to the high-field regime, where E/N can

exceed 100 Td, so the process of direct dissociation of CO₂ molecules by fast electrons dominates.

REFERENCES

1. R. Snoeckx, A. Bogaerts. Plasma technology - a novel solution for CO₂ conversion? // *Chem. Soc. Rev.* 2017, v. 46, p. 5805.
2. A. Bogaerts, G. Centi. Plasma Technology for CO₂ Conversion: A Personal Perspective on Prospects and Gaps // *Frontiers in Energy Research.* 2020, v. 8, p. 111.
3. G. Chen, R. Snyders, N. Britun. CO₂ conversion using catalyst-free and catalyst-assisted plasma-processes: Recent progress and understanding // *Journal of CO₂ Utilization.* 2021, v. 49, p. 101557.
4. A. Fridman. *Plasma chemistry.* Cambridge University Press, 2008.
5. J. Amouroux, P. Siffert. Carbon dioxide: a raw material and a future chemical fuel for a sustainable energy industry // *IOP Conference Series "Materials Science and Engineering"*. 2011, v. 19, p. 012001.
6. V. Ivanov, Ts. Paunskas, S. Lazarova, A. Bogaerts, St. Kolev. Gliding arc/glow discharge for CO₂ conversion: Comparing the performance of different discharge configurations // *Journal of CO₂ Utilization.* 2023, v. 67, p. 102300.
7. S.V. Dudin, A.N. Dakhov. Conversion of carbon dioxide in low-pressure plasma // *Problems of Atomic Science and Technology. Series "Plasma Physics" (118).* 2018, № 6, p. 194.
8. S. Dudin, V. Lisovskiy, P. Platonov, S. Rezunenko. Kinetic simulation of CO₂ conversion in low-pressure electrodeless plasma // *Problems of Atomic Science and Technology. Series "Plasma Physics" (142).* 2022, № 6, p. 84-88.
9. S.V. Dudin, A.V. Zykov, S.D. Yakovin. Plasma assisted conversion of carbon dioxide in low-pressure gas discharges // *Problems of Atomic Science and Technology. Series "Plasma Electronics and New Methods of Acceleration" (116).* 2019, № 4, p. 141.
10. V.A. Lisovskiy, S.V. Dudin, P.P. Platonov, V.D. Yegorenkov. Studying CO₂ conversion in dc glow discharge // *Problems of Atomic Science and Technology. Series "Plasma Physics" (130).* 2020, № 6, p. 179.
11. P.P. Platonov, S.V. Dudin, V.A. Lisovskiy. Simulation of gas dynamics in plasma reactor for carbon dioxide conversion // *Problems of Atomic Science and Technology. Series "Plasma Physics" (131).* 2021, № 1, p. 131.
12. V.A. Lisovskiy, S.V. Dudin, P.P. Platonov, R.O. Osmayev, V.D. Yegorenkov. Glow discharge with a hollow cathode in carbon dioxide // *Problems of Atomic Science and Technology. Series "Plasma Physics" (142).* 2022, № 6, p. 79-83.
13. T. Kaneda, T. Kubota, J-Ch. Chang. Plasma parameters in noble-gas narrow-tube and capillary-tube discharge, positive column plasmas // *J. Phys. D: Appl. Phys.* 1990, v. 23, p. 500-503.
13. V.A. Lisovskiy, K.P. Artushenko, V.D. Yegorenkov. Reduced electric field in the positive column of the glow discharge in argon // *Vacuum.* 2015, v. 122, p. 75-81.
14. V.A. Lisovskiy, K.P. Artushenko, V.D. Yegorenkov. Influence of the inter-electrode gap on the cathode sheath characteristics (voltage drop across it and its thickness) // *Physics of Plasmas.* 2017, v. 24, p. 053501.
15. V. Hoffmann, V.V. Efimova, M.V. Voronov, P. Šmíd, E.B.M. Steers, J. Eckert. Measurement of voltage and current in continuous and pulsed rf and dc glow discharges // *J. Phys.: Conf. Series.* 2008, v. 133, № 133, p. 012017.
16. V. Efimova, V. Hoffmann, J. Eckert. Electrical properties of the ms pulsed glow discharge in a Grimm-type source: comparison of dc and rf modes // *J. Anal. At. Spectrom.* 2011, v. 26, p. 784-791.
17. V.A. Lisovskiy, P.A. Ogloblina, S.V. Dudin, V.D. Yegorenkov, A.N. Dakhov. Current gain of a pulsed DC discharge in low-pressure gases // *Vacuum,* 2017, v. 145, p. 194-202.
18. V.A. Lisovskiy, S.V. Dudin, M.M. Vusyk, V.D. Yegorenkov. Burning modes of a bipolar pulsed discharge in CO₂ // *Problems of Atomic Science and Technology. Series "Plasma Physics" (130).* 2020, № 6, p. 159-164.
19. A.S. Morillo-Candas, C. Drag, J.-P. Booth, T.C. Dias, V. Guerra, O. Guaitella. Oxygen atom kinetics in CO₂ plasmas ignited in a DC glow discharge // *Plasma Sources Sci. Technol.* 2019, v. 28, p. 075010.

Article received 25.01.2023

КЕРУВАННЯ ЗВЕДЕНИМ ЕЛЕКТРИЧНИМ ПОЛЕМ У ПОЗИТИВНОМУ СТОВПІ ІМПУЛЬСНОГО РОЗРЯДУ В СО₂

В.О. Лісовський, С.В. Дудін, М.М. Вусик, Р.О. Осмаєв, В.Д. Єгоренков, П.П. Платонов

Методом рухомих електродів була визначена величина напруженості електричного поля у позитивному стовпі розряду постійного струму та біполярних імпульсних розрядів у вуглекислому газі. Показано, що підвищення частоти імпульсної напруги призводить до збільшення напруженості електричного поля у позитивному стовпі. Були отримані наступні величини зведеного електричного поля E/p , коли тиск газу становив 0,5 Торр: для розряду постійного струму 22,5 В/(см·Торр), так для імпульсного розряду з частотою 20 кГц значення зведеного електричного поля складало 30 В/(см·Торр) для слабкострумового режиму та 32 В/(см·Торр) для сильнострумового режиму і 36,6 В/(см·Торр) для частоти 75 кГц. Бачимо, що у розряді постійного струму зведене електричне поле E/N слабке, завдяки чому обмін коливальною енергією між молекулами СО₂ домінує при процесі конверсії. Збільшення напруженості електричного поля у позитивному стовпі імпульсного розряду, особливо за умов нагріву газу, дозволяє отримати $E/N > 100$ Тд, коли процес прямої дисоціації молекул СО₂ швидкими електронами дає основний вклад у процес конверсії.